



Owner's Manual

◆ SET-UP ◆ OPERATION ◆ MAINTENANCE



**IMPORTANT: Read
Safety Rules and
Instructions Carefully**

CALLING CUSTOMER SUPPORT

- **LOCATE YOUR MODEL NUMBER AND SERIAL NUMBER** which appears on your unit and record the information in the space provided below.

IMPORTANT: You must have these numbers, along with the date and proof of purchase to receive warranty or service.

- If you are having difficulty assembling this product or if you have any questions regarding the controls, operation or maintenance of this unit, please call the Customer Support Department.
- Customer Support can be reached by dialing: **1-800-668-1238**
- Please have your model number and serial number ready when you call.

NOTE: Although both numbers are important, you will be asked to enter only your serial number before your call can be processed.

Model Number Numéro de modèle	Serial Number Numéro de série
XXX-XXXXXX	XXXXXXXXXX
TROY-BILT TROYBILT - CANADA KITCHENER, ON N2G 4J1	

— This is where your model number will be, record model number here:

— This is where your serial number will be, record serial number here:

TABLE OF CONTENTS

CALLING CUSTOMER SUPPORT	2
TABLE OF CONTENTS	2
IMPORTANT SAFE OPERATION PRACTICES	3
SLOPE GAUGE.	6
SET-UP INSTRUCTIONS.	7
CONTROLS	8
OPERATION	9
ADJUSTMENT	12
LUBRICATION	13
MAINTENANCE.	13
OFF SEASON STORAGE INSTRUCTIONS.	17
REPLACEMENT PARTS/PIÈCES DÉTACHÉES.	18
WARRANTY:	29
TROUBLE SHOOTING	30

For more details about your unit, visit our website at www.mtdcanada.com

This unit has been inspected against the manufacturers quality check list. In case of a discrepancy, please call us. We will make every effort to ship the part(s) by courier within one working day of your call.

IMPORTANT SAFE OPERATION PRACTICES



WARNING: This symbol points out important safety instructions which, if not followed, could endanger the personal safety and/or property of yourself and others. Read and follow all instructions in this manual before attempting to operate this machine. Failure to comply with these instructions may result in personal injury. When you see this symbol—  heed its warning.



DANGER: This machine was built to be operated according to the rules for safe operation in this manual. As with any type of power equipment, carelessness or error on the part of the operator can result in serious injury. This machine is capable of amputating hands and feet and throwing objects. Failure to observe the following safety instructions could result in serious injury or death.

GENERAL OPERATION

- Read, understand, and follow all instructions on the machine and in the manual(s) before attempting to assemble and operate. Keep this manual in a safe place for future and regular reference and for ordering replacement parts.
- Be familiar with all controls and their proper operation. Know how to stop the machine and disengage them quickly.
- Never allow children under 14 years old to operate this machine. Children 14 years old and over should read and understand the operation instructions and safety rules in this manual and should be trained and supervised by a parent.
- Never allow adults to operate this machine without proper instruction.
- To help avoid blade contact or a thrown object injury, keep bystanders, helpers, children and pets at least 75 feet from the machine while it is in operation. Stop machine if anyone enters the area.
- Thoroughly inspect the area where the equipment is to be used. Remove all stones, sticks, wire, bones, toys and other foreign objects which could be tripped over or picked up and thrown by the blade. Thrown objects can cause serious personal injury.
- Plan your mowing pattern to avoid discharge of material toward roads, sidewalks, bystanders and the like. Also, avoid discharging material against a wall or obstruction which may cause discharged material to ricochet back toward the operator.
- Always wear safety glasses or safety goggles during operation and while performing an adjustment or repair to protect your eyes. Thrown objects which ricochet can cause serious injury to the eyes.
- Wear sturdy, rough-soled work shoes and close-fitting slacks and shirts. Shirts and pants that cover the arms and legs and steel-toed shoes are recommended. Never operate this machine in bare feet, sandals, slippery or light weight (e.g. canvas) shoes.
- Many injuries occur as a result of the mower being pulled over the foot during a fall caused by slipping or tripping. Do not hold on to the mower if you are falling; release the handle immediately.
- Never pull the mower back toward you while you are walking. If you must back the mower away from a wall or obstruction first look down and behind to avoid tripping and then follow these steps:
 - a) Step back from the mower to fully extend your arms.
 - b) Be sure you are well balanced with sure footing.
 - c) Pull the mower back slowly, no more than half way toward you.
 - d) Repeat these steps as needed.
- Do not operate the mower while under the influence of alcohol or drugs.
- Do not put hands or feet near rotating parts or under the cutting deck. Contact with the blade can amputate hands and feet.
- A missing or damaged discharge cover can cause blade contact or thrown object injuries.
- Do not engage the self-propelled mechanism on units so equipped while starting engine.
- Never attempt to make a wheel or cutting height adjustment while the engine is running.
- The blade control handle is a safety device. Never attempt to bypass its operation. Doing so makes the safety device inopera-

tive and may result in personal injury through contact with the rotating blade. The blade control handle must operate easily in both directions and automatically return to the disengaged position when released.

- Never operate the mower in wet grass. Always be sure of your footing. A slip and fall can cause serious personal injury. If you feel you are losing your footing, release the blade control handle immediately and the blade will stop rotating within three seconds.
- Mow only in daylight or in good artificial light. Walk, never run.
- Stop the blade when crossing gravel drives, walks or roads.
- If the equipment should start to vibrate abnormally, stop the engine and check immediately for the cause. Vibration is generally a warning of trouble.
- Shut the engine off and wait until the blade comes to a complete stop before removing the grass catcher or unclogging the chute. The cutting blade continues to rotate for a few seconds after the engine is shut off. Never place any part of the body in the blade area until you are sure the blade has stopped rotating.
- Never operate mower without proper trail shield, discharge cover, grass catcher, blade control handle or other safety protective devices in place and working. Never operate mower with damaged safety devices. Failure to do so, can result in personal injury.
- Muffler and engine become hot and can cause a burn. Do not touch.
- Only use parts and accessories made for this machine by the manufacturer. Failure to do so, can result in personal injury.
- If situations occur which are not covered in this manual, use care and good judgment. Contact your customer support department.

SLOPE OPERATION

Slopes are a major factor related to slip and fall accidents which can result in severe injury. Operation on slopes requires extra caution. If you feel uneasy on a slope, do not mow it. For your safety, use the slope gauge included as part of this manual to measure slopes before operating this unit on a sloped or hilly area. If the slope is greater than 15 degrees, do not mow it.

DO:

- Mow across the face of slopes; never up and down. Exercise extreme caution when changing direction on slopes. Watch for holes, ruts, bumps, rocks, or other hidden objects which can cause you to slip or trip. Tall grass can hide obstacles. Always be sure of your footing. A slip and fall can cause serious personal injury. If you feel you are losing your balance, release the blade control handle immediately, and the blade will stop rotating within 3 seconds.

DO NOT:

- Do not mow near drop-offs, ditches or embankments, you could lose your footing or balance.
- Do not mow slopes greater than 15 degrees as shown on the slope gauge.
- Do not mow on wet grass. Unstable footing could cause slipping.

CHILDREN

- Tragic accidents can occur if the operator is not alert to the presence of children. Children are often attracted to the mower and the mowing activity. They do not understand the dangers. Never assume that children will remain where you last saw them.
 - a) Keep children out of the mowing area and under the watchful care of a responsible adult other than the operator.
 - b) Be alert and turn mower off if a child enters the area.
 - c) Before and while moving backwards, look behind and down for small children.
 - d) Use extreme care when approaching blind corners, doorways, shrubs, trees, or other objects that may obscure your vision of a child who may run into the mower.
 - e) Keep children away from hot or running engines. They can suffer burns from a hot muffler.
- Never allow children under 14 years old to operate a power mower. Children 14 years old and over should read and understand the operation instructions and safety rules in this manual and should be trained and supervised by a parent.

SERVICE SAFE HANDLING OF GASOLINE:

- To avoid personal injury or property damage use extreme care in handling gasoline. Gasoline is extremely flammable and the vapors are explosive. Serious personal injury can occur when gasoline is spilled on yourself or

your clothes which can ignite. Wash your skin and change clothes immediately.

- a) Use only an approved gasoline container.
- b) Never fill containers inside a vehicle or on a truck or trailer bed with a plastic liner. Always place containers on the ground away from your vehicle before filling.
- c) When practical, remove gas-powered equipment from the truck or trailer and refuel it on the ground. If this is not possible, then refuel such equipment on a trailer with a portable container, rather than from a gasoline dispenser nozzle.
- d) Keep the nozzle in contact with the rim of the fuel tank or container opening at all times until fueling is complete. Do not use a nozzle lock-open device.
- e) Extinguish all cigarettes, cigars, pipes and other sources of ignition.
- f) Never fuel machine indoors.
- g) Never remove gas cap or add fuel while the engine is hot or running. Allow engine to cool at least two minutes before refueling.
- h) Never over fill fuel tank. Fill tank to no more than $\frac{1}{2}$ inch below bottom of filler neck to provide space for fuel expansion.
- i) Replace gasoline cap and tighten securely.
- j) If gasoline is spilled, wipe it off the engine and equipment. Move unit to another area. Wait 5 minutes before starting the engine.
- k) Never store the machine or fuel container inside where there is an open flame, spark or pilot light as on a water heater, space heater, furnace, clothes dryer or other gas appliances.
- l) To reduce fire hazard, keep machine free of grass, leaves, or other debris build-up. Clean up oil or fuel spillage and remove any fuel soaked debris.
- m) Allow machine to cool at least 5 minutes before storing.

GENERAL SERVICE:

- Never run an engine indoors or in a poorly ventilated area. Engine exhaust contains carbon monoxide, an odorless and deadly gas.
- Before cleaning, repairing, or inspecting, make certain the blade and all moving parts have stopped. Disconnect the spark plug wire and ground against the engine to prevent unintended starting.
- Check the blade and engine mounting bolts at frequent intervals for proper tightness. Also, visually inspect blade for damage (e.g., bent, cracked, worn) Replace blade with the original equipment manufacturer's (O.E.M.) blade only, listed in this manual. "Use of parts which do not meet the original equipment specifications may lead to improper performance and compromise safety!"
- Mower blades are sharp and can cut. Wrap the blade(s) or wear gloves, and use extra caution when servicing them.
- Keep all nuts, bolts, and screws tight to be sure the equipment is in safe working condition.
- Never tamper with safety devices. Check their proper operation regularly.
- After striking a foreign object, stop the engine, disconnect the spark plug wire and ground against the engine. Thoroughly inspect the mower for any damage. Repair the damage before starting and operating the mower.
- Grass catcher components, discharge cover, and trail shield are subject to wear and damage which could expose moving parts or allow objects to be thrown. For safety protection, frequently check components and replace immediately with original equipment manufacturer's (O.E.M.) parts only, listed in this manual. "Use of parts which do not meet the original equipment specifications may lead to improper performance and compromise safety!"
- Do not change the engine governor setting or overspeed the engine. The governor controls the maximum safe operating speed of the engine.
- Maintain or replace safety and instruction labels, as necessary.
- Observe proper disposal laws and regulations. Improper disposal of fluids and materials can harm the environment.

SI-102
7.23.03

OWNER'S
MANUAL



SAFETY LABEL



WARNING - Your Responsibility:

Restrict the use of this power machine to persons who read, understand and follow the warnings and instructions in this manual and on the machine.

SLOPE GAUGE

(Keep this sheet in a safe place for future reference.)

USE THIS SHEET AS A GUIDE TO DETERMINE SLOPES WHERE YOU MAY NOT OPERATE SAFELY.

SIGHT AND HOLD THIS LEVEL WITH A VERTICAL TREE

A POWER POLE

A CORNER OF A BUILDING

OR A FENCE POST

FOLD ON DOTTED LINE, REPRESENTING A 15° SLOPE

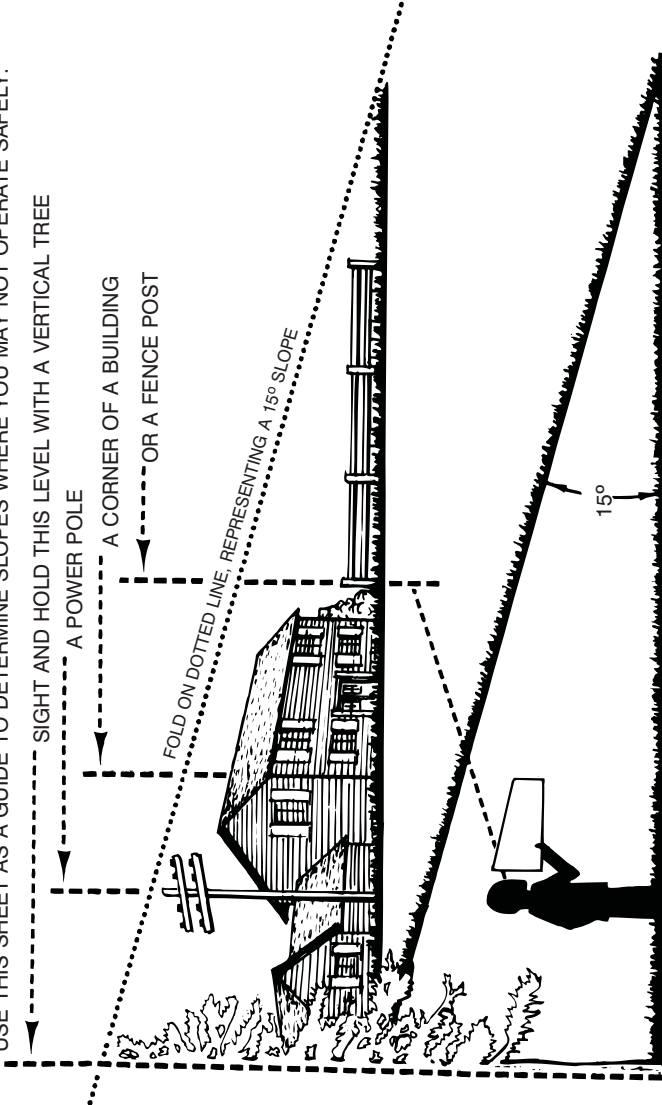

⚠ DANGER

Do not mow on inclines with a slope in excess of 15 degrees (a rise of approximately 2½ feet every 10 feet). A riding mower could overturn and cause serious injury. If operating a walk-behind mower on such a slope, it is extremely difficult to maintain your footing and you could slip, resulting in serious injury.

Operate RIDING mowers up and down slopes, never across the face of slopes.

Operate WALK-BEHIND mowers across the face of slopes, never up and down slopes.

SET-UP INSTRUCTIONS

This unit is shipped **WITHOUT GASOLINE or OIL**. After assembly, service engine with gasoline and oil as instructed in the separate engine manual packed with your unit.

NOTE: Reference to right or left hand side of the mower is observed from the operating position.

HOW TO SET-UP YOUR LAWN MOWER

Refer to Illustration Below

- Disconnect the spark plug wire and move it away from spark plug as instructed in the separate engine manual packed with your unit.
- Remove the carton inserts (if any). Remove the loose parts which are in the carton, lift the mower from the carton, or cut the corners of the carton and roll the mower out.
- Pull up and back on the upper handle to raise the handle into the operating position. See Figure 1. Make certain the lower handle is seated securely into the handle mounting brackets. Tighten the wing nuts on each side of the handle. See Figure 2.
- Remove the hairpin clips from the outer hole in the weld pins on the handle mounting

brackets. Place the hairpin clips in the inner hole. See Figure 2.

- Place one carriage bolt (found in the hardware pack included with your unit) in the upper hole of the right handle mounting bracket from the inside outward. Secure with one plastic wing nuts. Repeat process on other side. See Figure 2.

NOTE: Make certain the drive cable is routed around the outside and above the lower handle so it does not interfere with attaching the grass bag.

- The rope guide (pigs tail) is part of the grass catcher support rod attached to the lower handle. See Figure 3. With the **spark plug wire disconnected and grounded as instructed in the separate engine manual**, hold the blade control handle against the upper handle, and pull the starter rope out of the engine slowly until it extends past the rope guide (pigs tail).
- Guide the starter rope around the rope guide (pig tail) until the rope is securely in the center.
- Make certain all nuts and bolts are tightened securely.

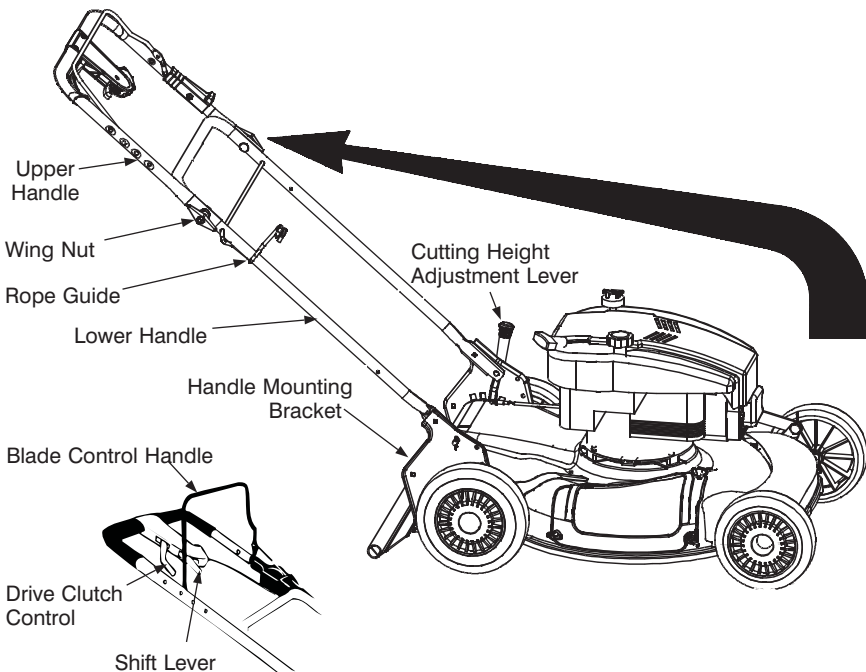
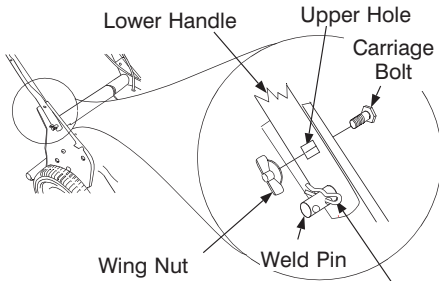

Figure 1



Place the hairpin clips in the inner hole.

Figure 2

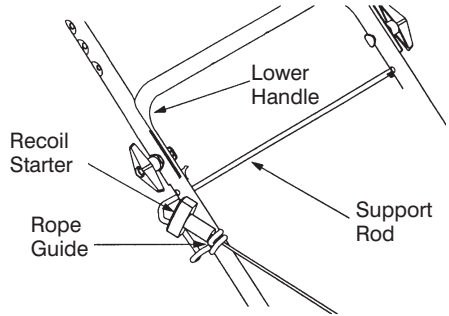

Figure 3

CONTROLS

BLADE CONTROL HANDLE

WARNING: This control mechanism is a safety device. Never attempt to bypass its operations.

The blade control handle is located on the upper handle of the mower. See Figure 1. The blade control handle must be depressed in order to operate the unit. Release the blade control handle to stop the engine and blade.

WARNING: The blade will be rotating whenever the engine is running.

RECOIL STARTER

The recoil starter handle is attached to the handle. See Figure 3. Stand behind the unit in the operating position to start the unit.

IGNITION SWITCH (Electric Start Units Only)

The ignition switch is located on the left side of the handle panel. It is used for starting only. See Figure 4.

DRIVE CLUTCH CONTROL

Squeezing the drive clutch control engages the drive system. Releasing the clutch control disengages the drive system. Release the clutch control to slow down when negotiating an obstacle, making a turn or stopping.

SHIFT LEVER

The shift lever is located on the drive clutch control housing on the upper handle. See Figure 1. This lever is used to select the forward speed of the mower. When changing your speed selection, release the drive clutch control.

Ignition Key (Switch)

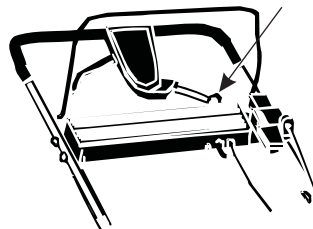

Figure 4-(Electric Start Units Only)

NOTE: Only move the shift lever when the engine is running. Changing the shift lever setting with the engine off can cause damage to the mower.

CUTTING HEIGHT ADJUSTMENT LEVER (Models: 959 & 979)

The height adjuster determines the cutting height of the mower. The adjuster is located above the left rear wheel. To adjust the cutting height, pull the lever out and away from the mower and then move it forward or back to select a new cutting height. See Figure 5.

CUTTING HEIGHT ADJUSTMENT LEVER (Model: 999)

The **rear wheel** height adjuster determines the cutting height of the mower. The adjuster is located above the left rear wheel. To adjust the cutting height, pull the lever out and away from the mower and then move it forward or back to select a new cutting height. See Figure 5.

The **front wheel** cutting height is determined by the selection of one of six positions in each caster assembly. See Figure 6.

To adjust, remove the wing nut from the axle bolt. Slide the axle bolt and spring washer from the assembly and select a cutting

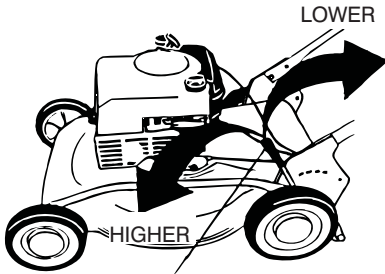

Cutting Height Adjustment Lever

Figure 5

height. With the spring washer on the axle bolt reinsert in the square hole desired, through the wheel assembly and secure with the wing nut previously removed.

IMPORTANT: All wheels must be placed in the same relative position.

NOTE: For rough or uneven lawns, move the height adjustment lever to a higher position. This will help stop scalping.

CASTER LOCK



WARNING: When operating mower on hills, front wheels should be locked in the straight ahead position.

The casters can be locked in a straight ahead position or can be left to swivel freely. Lift and place the lock pins in the larger holes for locked, straight ahead operation, place pins in smaller holes to allow casters to rotate freely.

OPERATION

IMPORTANT: Move the shift lever **ONLY** when the engine is running. Shifting the speeds with the engine off can cause damage to the unit. Disengage the drive clutch control before changing the speed selection.

Service the engine with gasoline and oil as instructed in the separate engine manual packed in your mower. Read instructions carefully.



WARNING: Never fill fuel tank indoors, with engine running or until the engine has been allowed to cool for at least two minutes after running.

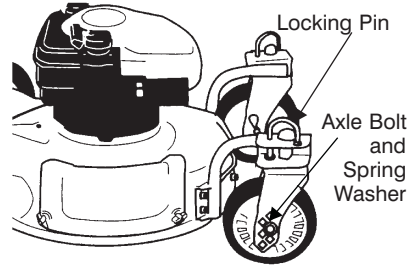

Figure 6

BEFORE STARTING

MODELS WITH ELECTRIC START ONLY:



WARNING: The battery contains corrosive fluid and toxic material. **HANDLE WITH CARE.** Keep away from children. Do not puncture, disassemble, mutilate or incinerate. Explosive gases could be vented during charging or discharging. Use in a well-ventilated area, away from sources of ignition.

- Charge battery for 16 hours before initial use. **DO NOT CHARGE LONGER THAN 20 HOURS.**

IMPORTANT: Use only the battery charger supplied with this mower.

To charge the battery, first remove the protective cap from the end of the battery pack lead. Always plug charger lead into battery pack lead before inserting battery charger plug into 120 volt standard household outlet. See Figure 7.

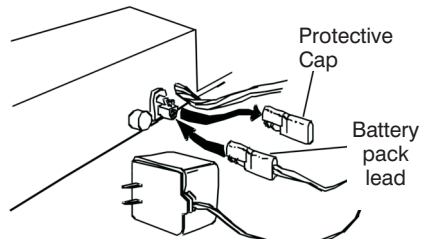

Figure 7

After charging, disconnect battery charger plug from household outlet first, then disconnect charger lead from battery pack lead.

WARNING: Do not remove the battery pack from the handle panel for any reason other than replacement. When replacing the battery pack, refer to instructions in Maintenance section.

NEUTRAL TEST FOR ALL MODELS:

- Before each use, check for proper drive clutch operation by performing the following before starting the engine:

With the drive clutch control released, push mower forward. It should move freely.

If it does not and the rear wheels tend to lock up, the clutch may not be releasing completely. Do not start the engine until corrections have been made. Check the control cable for severe bend, kinks and binding, or grass build-up in the pulley groove. Refer to the "Adjustment" section for any additional information.

TO START ENGINE AND ENGAGE BLADE

WARNING: When starting the unit for the first time, place mower in first speed (slow) position. Face the mower against a solid object such as a wall, fence, etc. Start the unit, and if it shows any signs of motion with the drive clutch control disengaged, shut the engine off immediately. Make certain the drive clutch control is adjusted so the drive belt is as loose as possible. Refer to the Adjustment Section.

- Attach spark plug wire to spark plug. If unit is equipped with a rubber boot over the end of the spark plug wire, make certain the metal loop on the end of the spark plug wire (inside the rubber boot) is fastened securely over the metal tip on the spark plug. See Figure 8.

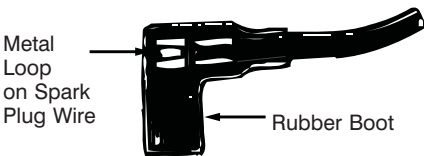

Figure 8

- If your unit is equipped with a primer, prime engine as instructed in the separate engine manual packed with your unit.
- If your unit is equipped with a two speed control on the engine refer to the separate engine manual packed with your unit.

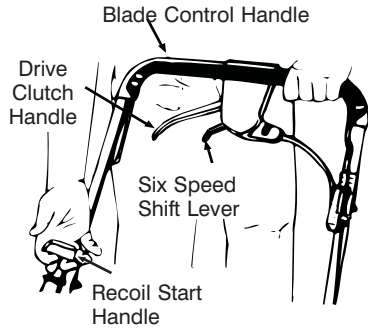

Figure 9-RECOIL START MODEL SHOWN

- Standing behind the unit, depress the blade control handle and hold it against the upper handle as shown in Figure 9.

ELECTRIC START MODELS ONLY:

- Turn the ignition key to the right to start the engine. Release the key after engine starts. See Figure 4.

NOTE: The engine on your unit is provided with an auxiliary recoil starter system. To start the engine using the auxiliary start system, proceed as follows for recoil start models:

RECOIL START MODELS ONLY:

- Grasp the recoil starter handle as shown and pull slowly until resistance is felt, then pull rapidly to start engine and avoid kickback. Return it slowly to the rope guide bolt. See Figure 9.
- To engage the drive, squeeze the drive clutch control handle (see Figure 9) towards the upper handle. Release the drive clutch control to slow down when negotiating an obstacle, making a turn, or stopping.
- The six speed shift lever is located on the drive clutch control housing on the upper handle. See Figure 9. This lever is used to select the operating speed of the mower. Release the drive clutch control when changing speeds.

WARNING: THIS CONTROL MECHANISM IS A SAFETY DEVICE. NEVER ATTEMPT TO BYPASS ITS OPERATIONS.

The blade control handle must be depressed in order to operate the unit. Release the blade control handle to stop the engine and blade.

TO STOP ENGINE

- Release the blade control handle to stop the engine and blade.



WARNING: The blade continues to rotate for a few seconds after the engine is shut off.

- Disconnect the spark plug wire and ground it against the engine as instructed in the separate engine manual to prevent accidental starting while equipment is unattended.

USING YOUR ROTARY MOWER

Be sure that lawn is clear of stones, sticks, wire, or other objects which could damage lawn mower or engine. Such objects could be accidentally thrown by the mower in any direction and cause serious personal injury to the operator and others.

For the best results, do not cut wet grass because it tends to stick to the underside of the mower, preventing proper mulching of grass clippings. In addition, wet grass could cause you to slip and fall. New grass, thick grass or wet grass may require a narrower cut.

For best results, cut off one-third or less of the total length of the grass. Lawn should be cut in the fall as long as there is growth.

The mower is designed to be operated at full throttle to give you the best cut and do the most effective job of mulching.



WARNING: If you strike a foreign object, stop the engine. Remove wire from spark plug, thoroughly inspect the mower for any damage, and repair the damage before restarting and operating the mower. Extensive vibration of the mower during operation is an indication of damage. The unit should be promptly inspected and repaired.

BAGGING GRASS CLIPPINGS

This mower can bag grass clippings. Follow steps 1 through 3 to ready the mower for bagging.

1. Remove wing nuts holding mulching baffle (see Figure 10) or side discharge chute (see Figure 14) in place. Then remove baffle or discharge chute.
2. Replace with bagging adapter (see Figure 11). Attach using wing nuts. Be sure that inner lip of attachment goes under the edge of the deck.
3. Lift flap and slide bag onto adapter. See Figure 12.

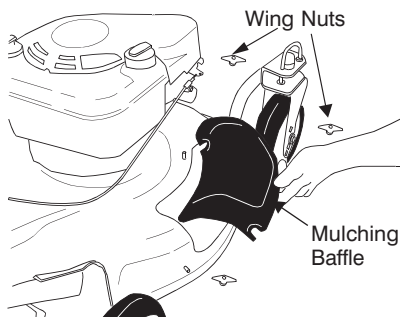

Figure 10

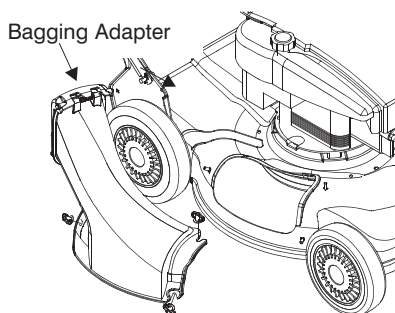

Figure 11

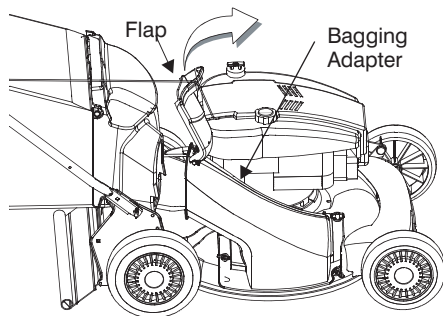

Figure 12

EMPTYING YOUR GRASS BAG

Lift grassbag from the bagging adapter using the lower handle. While holding the lower handle lift up the rear section of the grassbag. The bag will open and the grass clippings will fall out. See Figure 13. When replacing your grassbag be sure the top of the bag rests on the wire support between the handles.



Figure 13

SIDE DISCHARGE GRASS CLIPPINGS

This mower can also side discharge grass clippings. Follow steps 1 and 2 to ready this mower for side discharge operation.

1. Remove mulching baffle or grass bag adapter. See Figure 10.
2. Attach discharge chute with wing nuts. See Figure 14.

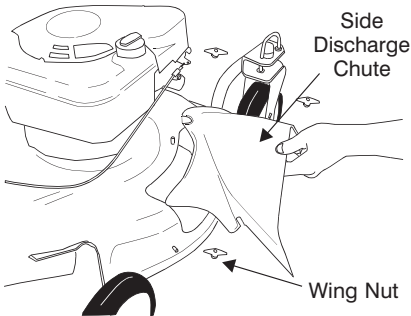

Figure 14

ADJUSTMENT

CAUTION: DO NOT AT ANY TIME MAKE ADJUSTMENTS TO LAWNMOWER WITHOUT FIRST STOPPING THE ENGINE AND DISCONNECTING THE SPARK PLUG WIRE

CAUTION: Before changing mowing height, stop mower and disconnect spark plug cable.

MODELS WITH SINGLE LEVER HEIGHT ADJUSTERS:

Refer to "Controls Section" and Figure 5.

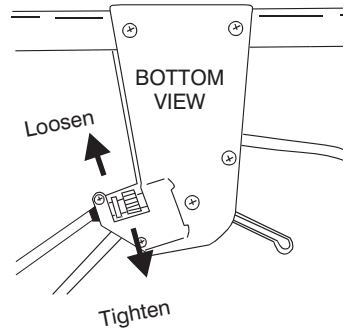

Figure 15

DRIVE CLUTCH CONTROL ADJUSTMENT

Use the adjustment wheel located on the underside of the clutch control housing to tighten the drive belt if mower does not self-propel with the drive clutch control engaged, or if drive belt is slipping (unit hesitates while engine maintains the same speed). See Figure 15.

In addition, the adjustment wheel may also be used to determine the position in which the drive clutch control is engaged. If it is more comfortable to have the drive engaged with the lever further away from the handle, tighten the drive belt.

Make certain to retest the unit for neutral as instructed in the operation Section. Move the adjustment wheel in the opposite direction to loosen the drive belt if necessary.

SIX SPEED SHIFT CABLE ADJUSTMENT

Periodic adjustment of the six speed shift cable may be required due to normal stretch and wear on the cable. Adjustment is needed if all six speeds cannot be obtained.

The adjustable cable bracket is located on the left side of the mower, beside the engine. To adjust, loosen the hex nut which secures the adjustable cable bracket. See Figure 16. Pull backward on the bracket (toward the rear of the mower). Retighten the hex nut. Test the speeds on the mower (engine must be running).

CARBURETOR ADJUSTMENT

Refer to the separate engine manual packed with your mower for carburetor adjustment information.

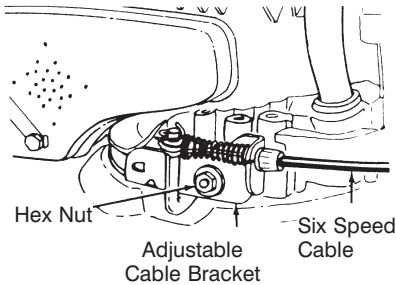

Figure 16

LUBRICATION

CAUTION: DISCONNECT SPARK PLUG WIRE BEFORE SERVICING.

WHEELS - If your mower is equipped with ball bearing wheels, lubricate at least once a season with a light oil, all other types require no lubrication. However, if the wheels are removed for any reason, lubricate the surface of the axle bolt and the inner surface of the wheel with light automotive oil.

ENGINE - Follow engine manual for lubrication instructions.

BLADE CONTROL - Lubricate the pivot points on the blade control handle and the brake cable at least once a season with light oil. The blade control must operate freely in both directions.

TRANSMISSION - The transmission is pre-lubricated and sealed at the factory. It does not require checking. If disassembled for any reason, fill with 2 ounces of Alvania grease, part number 737-0168.

MAINTENANCE

For best results your blade should be sharp. The blade may be resharpened by removing it and either grinding or filing the cutting edge keeping as close to the original bevel as possible.

Improper blade balance will result in excessive vibration causing eventual damage to the engine and mower. Be sure to carefully balance blade after sharpening.

After prolonged use, especially in sandy soil conditions, the blade will become worn and lose some of the original shape. Cutting efficiency will be reduced and the blade should be replaced. Replace with an approved factory

replacement blade only. Possible damage resulting from blade unbalance condition is not the responsibility of the manufacturer.

ENGINE

Refer to the separate engine manual for engine maintenance instructions.

Maintain **engine oil** as instructed in the separate engine manual packed with your unit. Read and follow instructions carefully.

Under normal conditions service **air cleaner** as instructed in the separate engine manual packed with your unit. Clean every few hours under extremely dusty conditions. Poor engine performance and flooding usually indicates that the air cleaner should be serviced.

The **spark plug** should be cleaned and the gap reset once a season. Spark plug replacement is recommended at the start of each mowing season; check engine manual for correct plug type and gap specifications.

NOTE: *This spark ignition system meets all requirements of the Canadian Interference-Causing Equipment Regulations.*

Clean the engine regularly with a cloth or brush. Keep the cooling system (blower housing area) clean to permit proper air circulation which is essential to engine performance and life. Be certain to remove all grass, dirt and combustible debris from muffler area.

DECK

The underside of the mower deck should be cleaned after each use to prevent a buildup of grass clippings, leaves, dirt or other matter. If this debris is allowed to accumulate, it will invite rust and corrosion, and may prevent proper mulching.

The deck may be cleaned by tilting the mower and scraping clean with a suitable tool (make certain the spark plug wire is disconnected).

CUTTING BLADE

 **WARNING:** Be sure to disconnect and ground the spark plug wire and remove ignition key before working on the cutting blade to prevent accidental engine starting. Protect hands by using heavy gloves or a rag to grasp the cutting blade.

Tip mower as specified in separate engine manual. If it is not specified tip with carburetor up.

Remove the bolt and blade support which holds the blade and adapter to the engine crankshaft. Remove the blade and adapter from the crankshaft.

WARNING: Periodically inspect the blade adapter for cracks, especially if you strike a foreign object. Replace when necessary.

For best results your blade should be sharp. The blade may be resharpened by removing it and either grinding or filing the cutting edge keeping as close to the original bevel as possible. It is **extremely** important that each cutting edge receives an equal amount of grinding to prevent an unbalanced blade. Improper blade balance will result in excessive vibration causing eventual damage to the engine and mower. Be sure to carefully balance blade after sharpening. The blade can be tested for balance by balancing it on a round shaft screwdriver. Remove metal from the heavy side until it balances evenly.

Before reassembling the blade and the blade adapter to the unit, lubricate the engine crankshaft and the inner surface of the blade adapter with light oil. Install the blade adapter on the crankshaft with the "star" away from the engine. Refer to Figure 18. Place the blade with the side marked bottom (or with part number) facing away from the adapter. Align the blade bell support over the blade with the tabs in the holes of the blade and insert the hex bolt. Tighten the hex bolt to the torque listed below:

Blade Mounting Torque

Center Bolt 450 in. lb. min., 600 in.lb. max.

To insure safe operation of your unit, ALL nuts and bolts must be checked periodically for correct tightness.

CAUTION: Cutting grass in sandy soil conditions causes abrasive wear to the blade.

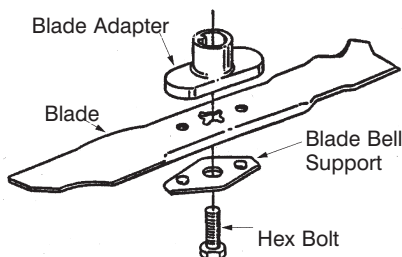

Figure 18

After prolonged use, especially in sandy soil conditions, the blade will become worn and lose some of the original shape. Cutting efficiency will be reduced and the blade should be replaced. Replace with an approved factory replacement blade only. Possible damage resulting from blade unbalance condition is not the responsibility of the manufacturer.

BELT REMOVAL AND REPLACEMENT

1. Disconnect the spark plug wire and ground it against the engine.
2. Drain the fuel tank or place a piece of plastic beneath the cap to prevent gasoline leakage.
3. Tip the mower on its side. Block securely.
4. Remove the blade and blade adapter as described previously.
5. Move rear height adjuster to the highest position. See Figure 21.
6. Using a 3/8" socket remove three hex screws holding the baffle to the deck. See Figure 19.

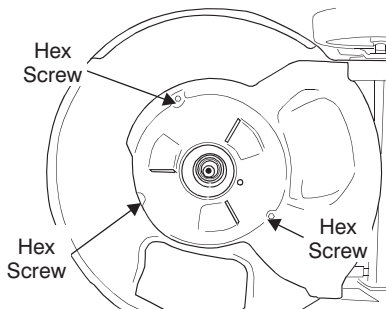

Figure 19

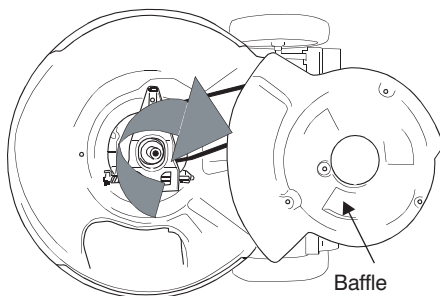

Figure 20

7. Pivot baffle towards the rear of the mower. See Figure 20.
8. Remove the hex bolt holding the transmission to the mower housing. See Figure 21.

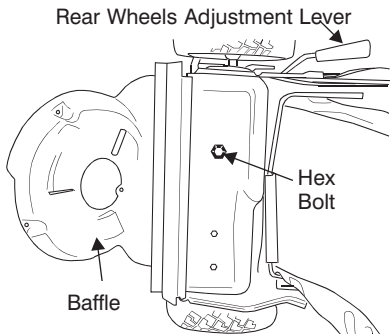

Figure 21

9. Tilt the transmission forward and loosen the idler pulley bolt and locknut $\frac{1}{2}$ turn using two $\frac{7}{16}$ " wrenches.
10. Using a pair of pliers, pull back and rotate belt keeper bracket from the slot on idler pulley.
11. Slide the belt out from between the belt keeper bracket and the idler pulley. See Figure 22.
12. Squeeze the belt together and push belt forward. Press the control arm inward towards the deck and remove the six speed cable from the slot. See Figure 23.

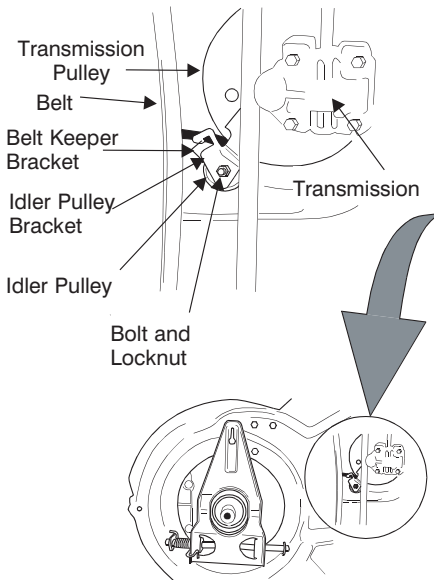

Figure 22

Mower is shown tipped on engine for clarity. Remember, only tip mower back on its handle with the spark plug facing up.

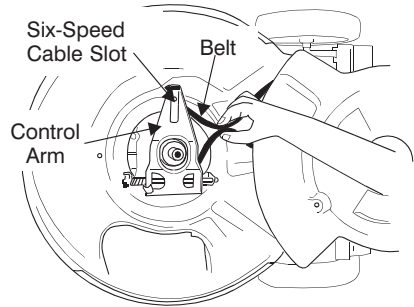

Figure 23

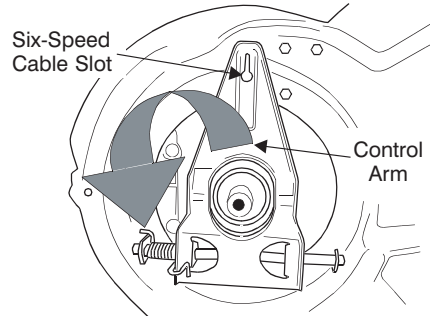

Figure 24

13. Pivot the control arm down away from the pulley and belt. See Figure 24.
14. Lift off the lower pulley assembly and remove the old belt from around the crankshaft. See Figure 25.
15. Place the new belt over the transmission pulley. Start the belt in pulley groove and rotate pulley until belt is seated in transmission pulley. See Figure 25.
16. Place belt between idler pulley and the belt keeper bracket.

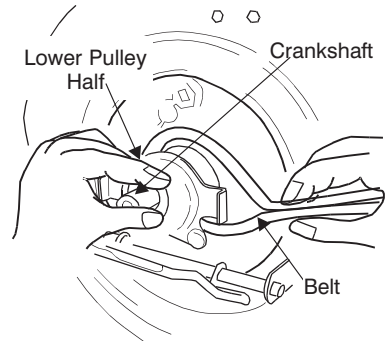

Figure 25

17. Using pliers, rotate the belt keeper bracket so that it snaps into slot on the idler bracket.
18. Tighten the idler pulley bolt and locknut $\frac{1}{2}$ turn using two $\frac{7}{16}$ " wrenches. See Figure 22.
19. Place belt between the two pulley halves on the crankshaft. Make sure to route the belt inside the belt guard pin. See Figure 26.

IMPORTANT: For proper assembly, it is essential to keep the assembly positioned as shown in Figure 26.

20. Pinch belt together so that it is not in the pulley groove, and the lower pulley can be pushed towards the engine. See Figure 27.
21. Pivot the control arm back to its original position and reinstall the six-speed cable into the slot.
22. Check and make sure the belt is routed inside the pulley halves and the belt guard pin. See Figure 28.
23. Reinstall the bolt securing transmission to rear mower housing.
24. Pivot the baffle back to its original position and secure with three hex screws earlier removed. You will need a $\frac{3}{8}$ " socket for these screws.
25. Lightly lubricate the crankshaft and reinstall blade and blade adapter as described in the "Cutting Blade" section.
26. Tip the mower back on its wheels.
27. Make certain to retest the unit for neutral as instructed in the Operation Section.

BATTERY PACK REPLACEMENT (Electric start Models Only)

Remove the battery pack from the handle panel for replacement only. Do not separate the batteries for any reason. Dispose of batteries properly.

! WARNING: Batteries contain sulfuric acid which may cause burns. Do not short circuit or mutilate in any way. Do not put batteries in fire. They may burst or release toxic material.

When replacing battery pack in handle panel, battery pack must be positioned with the positive terminal to the right hand side and the negative terminal to the left hand side of panel. See Figure 29. Replacing the battery pack incorrectly will cause serious damage.

The positive lead on the wire harness has the smaller connector. Connect the positive

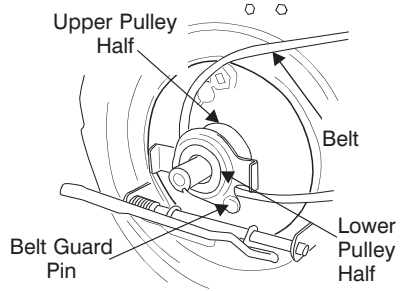

Figure 26

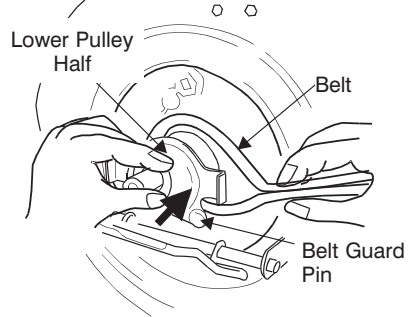

Figure 27

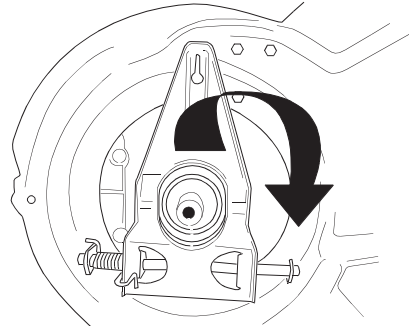

Figure 28

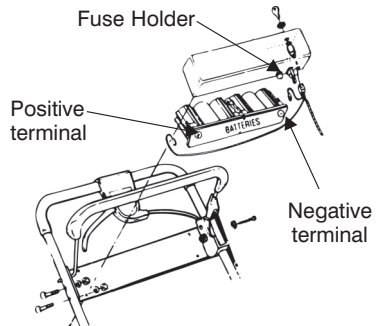

Figure 29

lead to the positive side of the battery pack, then connect the negative side.

IN-LINE FUSE

The unit is equipped with an in-line fuse. If unit fails to start, check the fuse inside the battery cover by turning the end of the fuse holder and removing from the battery cover. See Figure 29. Replace with standard automotive 7-1/2 amp fuse.

OFF SEASON STORAGE INSTRUCTIONS

The following steps should be taken to prepare lawn mower for storage.

1. Clean and lubricate mower thoroughly as described in the lubrication instructions.
2. Refer to engine manual for correct engine storage instructions.
3. Coat mower's cutting blade with chassis grease to prevent rusting.
4. Store mower in a dry, clean area.

STORAGE OF THE BATTERY

The battery must be stored with a full charge. A discharge battery will freeze.

IMPORTANT: All batteries discharge during storage.

Recharge battery every two months and before returning to service. Refer to charging instructions on page 9.

NOTE: *When storing any type of power equipment in an unventilated or metal storage shed, care should be taken to rust-proof the equipment. Using a light oil or silicone, coat the equipment, especially cables and all moving parts.*

CAUTION: **Never fold or unfold handle without disconnecting spark plug.**

NOTE: *Be careful not to bend or kink cables.*

NOTE: *If the starter rope becomes disconnected from rope guide on handle, disconnect and ground the spark plug wire. Depress the bail and pull the starter rope out from engine slowly. Slip the starter rope into the rope guide bolt on handle.*

TWO YEAR LIMITED WARRANTY

For TWO YEARS from the date of retail purchase within Canada, MTD PRODUCTS LIMITED will, at its option, repair or replace, for the original purchaser, free of charge, any part or parts found to be defective in material or workmanship.

This warranty does not cover:

1. Any part which has become inoperative due to misuse, commercial use, abuse, neglect, accident, improper maintenance or alteration; or
2. The unit if it has not been operated and/or maintained in accordance with the owner's instructions furnished with the unit; or
3. The engine or motor or component parts thereof which carry separate warranties from their manufacturers. Please refer to the applicable manufacturer's warranty on these items; or
4. Batteries and normal wear parts except as noted below. Log splitter pumps, valves and cylinders or component parts thereof are covered by a one year warranty; or
5. Routine maintenance items such as lubricants, filters, blade sharpening and tune-ups, or adjustments such as brake, clutch or deck; or
6. Normal deterioration of the exterior finish due to use or exposure.

Full Ninety Day Warranty on Battery: For ninety (90) days from the date of retail purchase, if any battery included with this unit proves defective in material or workmanship and our testing determines the battery will not hold a charge, MTD PRODUCTS LIMITED will replace the battery at no charge to the original purchaser.

Additional Limited Thirty Day Warranty on Battery: After ninety (90) days but within one hundred twenty (120) days from the date of purchase, MTD PRODUCTS LIMITED will replace the defective battery, for the original purchaser, for a cost of one-half (1/2) of the current retail price of the battery in effect at the date of return.

Full Sixty Day Warranty on Normal Wear Parts: Normal wear parts are defined as belts, blade adapters, blades, grass bags, seats, tires, rider deck wheels and clutch parts (friction wheels). These parts are warranted to the original purchaser to be free from defects in material and workmanship for a period of sixty (60) days from the date of retail purchase.

How to Obtain Service: Warranty service is available, with proof of purchase, through your local authorized service dealer or distributor. If you do not know the dealer or distributor in your area, please call, toll free 1-800-668-1238. The return of a complete unit will not be accepted by the factory unless prior written permission has been extended by MTD PRODUCTS LIMITED.

Transportation Charges: Transportation charges for the movement of any power equipment unit or attachment are the responsibility of the purchaser. Transportation charges for any part submitted for replacement under this warranty must be paid by the purchaser unless such return is requested in writing by MTD PRODUCTS LIMITED.

Other Warranties: All other warranties, express or implied, including any implied warranty of merchantability is limited in its duration to that set forth in this express limited warranty. The provisions as set forth in this warranty provide the sole and exclusive remedy of MTD PRODUCTS LIMITED obligations arising from the sale of its products.

MTD PRODUCTS LIMITED will not be liable for incidental or consequential loss or damage.

TROUBLE SHOOTING

PROBLEM	POSSIBLE CAUSE(S)	CORRECTIVE ACTION
Engine fails to start	<ol style="list-style-type: none"> 1. Blade control handle disengaged. 2. Spark plug wire disconnected. 3. Fuel tank empty, or stale fuel. 4. Blocked fuel line. 5. Faulty spark plug. 6. Engine flooded. 	<ol style="list-style-type: none"> 1. Engage blade control handle. 2. Connect spark plug wire. 3. Fill tank with clean, fresh gasoline. 4. Clean the fuel line. 5. Clean, adjust gap or replace. 6. Wait a few minutes to restart, but do not prime.
Engine runs erratic	<ol style="list-style-type: none"> 1. Spark plug wire loose. 2. Blocked fuel line or stale fuel. 3. Vent in gas plugged. 4. Water or dirt in fuel system. 5. Dirty air cleaner. 6. Carburetor out of adjustment. 	<ol style="list-style-type: none"> 1. Connect and tighten spark plug wire. 2. Clean the fuel line; fill the tank with clean, fresh gasoline. 3. Clear vent. 4. Drain the fuel tank and carburetor. Refill with fresh fuel. 5. Clean air cleaner. 6. Adjust carburetor.
Engine overheats	<ol style="list-style-type: none"> 1. Engine oil level low. 2. Air flow restricted. 3. Carburetor not adjusted properly. 	<ol style="list-style-type: none"> 1. Fill crankcase with proper oil. 2. Remove blower housing and clean. 3. Adjust carburetor.
Idles poorly	<ol style="list-style-type: none"> 1. Spark plug fouled, faulty or gap too wide. 2. Carburetor improperly adjusted. 3. Dirty air cleaner. 	<ol style="list-style-type: none"> 1. Reset gap to .030" or replace spark plug. 2. Adjust carburetor. 3. Clean air cleaner.
Excessive vibration	<ol style="list-style-type: none"> 1. Cutting blade loose or unbalanced. 2. Bent cutting blade. 	<ol style="list-style-type: none"> 1. Tighten blade and adapter. Balance blade. 2. Replace blade.
Mower will not mulch grass	<ol style="list-style-type: none"> 1. Wet grass. 2. Excessively high grass. 3. Dull blade. 	<ol style="list-style-type: none"> 1. Do not mow when grass is wet; wait until later to cut. 2. Mow once at a high cutting height, then mow again at desired height or make a narrower cutting path. 3. Sharpen or replace blade.
Uneven cut	<ol style="list-style-type: none"> 1. Wheels not positioned correctly. 2. Dull blade. 	<ol style="list-style-type: none"> 1. Place all four wheels in same height position. 2. Sharpen or replace blade.
Wheels will not propel	<ol style="list-style-type: none"> 1. Belt not installed properly. 2. Debris clogging drive operation. 	<ol style="list-style-type: none"> 1. Check belt for proper pulley installation and movement. 2. Clean out debris.

NOTE: For repairs beyond the minor adjustments listed above, contract your nearest authorized service dealer.