

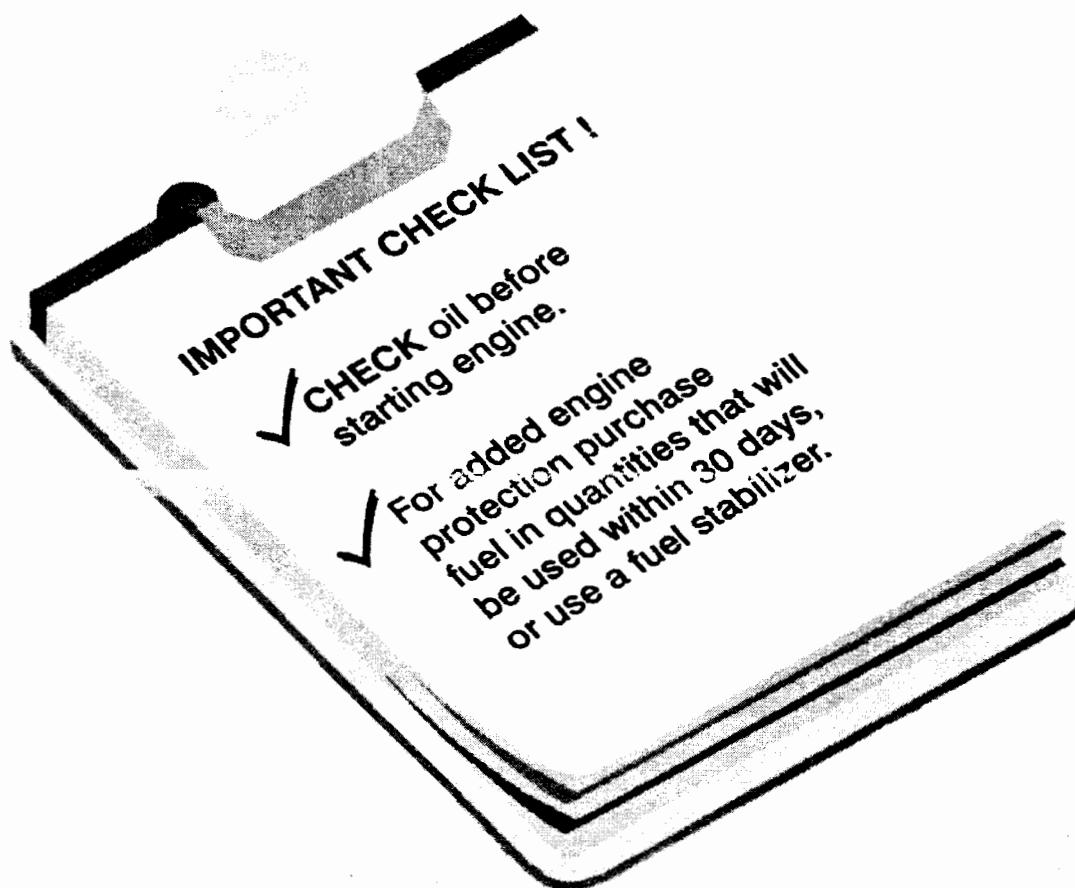

Owner's Manual

◆ SET-UP ◆ OPERATION ◆ MAINTENANCE



IMPORTANT: Read Safety Rules and Instructions Carefully

CALLING CUSTOMER SUPPORT

- **LOCATE YOUR MODEL NUMBER AND SERIAL NUMBER** which appears on your unit and record the information in the space provided below.

IMPORTANT: You must have these numbers, along with the date and proof of purchase to receive warranty or service.

- If you are having difficulty assembling this product or if you have any questions regarding the controls, operation or maintenance of this unit, please call an authorized dealer.
- Please have your model number and serial number ready when you call.

NOTE: Although both numbers are important, you will be asked to enter only your serial number before your call can be processed.

<table style="width: 100%; border-collapse: collapse;"> <tr> <td style="width: 50%; padding: 2px;"> <table style="width: 100%; border-collapse: collapse;"> <tr> <td style="font-size: small;">Model Number Numéro de modèle</td> <td style="font-size: small;">Serial Number Numéro de série</td> </tr> <tr> <td style="text-align: center; border-bottom: 1px solid black;">XXX-XXXXXX</td> <td style="text-align: center; border-bottom: 1px solid black;">XXXXXXXXXXXX</td> </tr> </table> </td> <td style="width: 50%; padding: 2px;"> <p style="font-size: small;">This is where your model number will be, record model number here:</p> <hr style="border: 0; border-top: 1px solid black;"/> </td> </tr> <tr> <td style="padding: 2px;"> <p style="font-size: small;">This is where your serial number will be, record serial number here:</p> <hr style="border: 0; border-top: 1px solid black;"/> </td> </tr> </table>	<table style="width: 100%; border-collapse: collapse;"> <tr> <td style="font-size: small;">Model Number Numéro de modèle</td> <td style="font-size: small;">Serial Number Numéro de série</td> </tr> <tr> <td style="text-align: center; border-bottom: 1px solid black;">XXX-XXXXXX</td> <td style="text-align: center; border-bottom: 1px solid black;">XXXXXXXXXXXX</td> </tr> </table>	Model Number Numéro de modèle	Serial Number Numéro de série	XXX-XXXXXX	XXXXXXXXXXXX	<p style="font-size: small;">This is where your model number will be, record model number here:</p> <hr style="border: 0; border-top: 1px solid black;"/>	<p style="font-size: small;">This is where your serial number will be, record serial number here:</p> <hr style="border: 0; border-top: 1px solid black;"/>	<p style="font-size: small;">This is where your serial number will be, record serial number here:</p> <hr style="border: 0; border-top: 1px solid black;"/>
<table style="width: 100%; border-collapse: collapse;"> <tr> <td style="font-size: small;">Model Number Numéro de modèle</td> <td style="font-size: small;">Serial Number Numéro de série</td> </tr> <tr> <td style="text-align: center; border-bottom: 1px solid black;">XXX-XXXXXX</td> <td style="text-align: center; border-bottom: 1px solid black;">XXXXXXXXXXXX</td> </tr> </table>	Model Number Numéro de modèle	Serial Number Numéro de série	XXX-XXXXXX	XXXXXXXXXXXX	<p style="font-size: small;">This is where your model number will be, record model number here:</p> <hr style="border: 0; border-top: 1px solid black;"/>			
Model Number Numéro de modèle	Serial Number Numéro de série							
XXX-XXXXXX	XXXXXXXXXXXX							
<p style="font-size: small;">This is where your serial number will be, record serial number here:</p> <hr style="border: 0; border-top: 1px solid black;"/>								





TABLE OF CONTENTS

CALLING CUSTOMER SUPPORT	2
TABLE OF CONTENTS	2
IMPORTANT SAFE OPERATION PRACTICES	3
SLOPE GAUGE	6
UNPACKING	7
ASSEMBLY	7
CONTROLS	9
OPERATION	10
ADJUSTMENTS	12
LUBRICATION	12
MAINTENANCE	12
OFF SEASON STORAGE INSTRUCTIONS	14
TROUBLE SHOOTING	15
REPLACEMENT PARTS/PIÈCES DÉTACHÉES	16
WARRANTY	21

This unit has been inspected against the manufacturers quality check list. In case of a discrepancy, please call us. We will make every effort to ship the part(s) by courier within one working day of your call.

IMPORTANT SAFE OPERATION PRACTICES



WARNING: This symbol points out important safety instructions which, if not followed, could endanger the personal safety and/or property of yourself and others. Read and follow all instructions in this manual before attempting to operate this machine. Failure to comply with these instructions may result in personal injury. When you see this symbol—  heed its warning.



DANGER: This machine was built to be operated according to the rules for safe operation in this manual. As with any type of power equipment, carelessness or error on the part of the operator can result in serious injury. This machine is capable of amputating hands and feet and throwing objects. Failure to observe the following safety instructions could result in serious injury or death.

GENERAL OPERATION

- Read, understand, and follow all instructions on the machine and in the manual(s) before attempting to assemble and operate. Keep this manual in a safe place for future and regular reference and for ordering replacement parts.
- Be familiar with all controls and their proper operation. Know how to stop the machine and disengage them quickly.
- Never allow children under 14 years old to operate this machine. Children 14 years old and over should read and understand the operation instructions and safety rules in this manual and should be trained and supervised by a parent.
- Never allow adults to operate this machine without proper instruction.
- To help avoid blade contact or a thrown object injury, keep bystanders, helpers, children and pets at least 75 feet from the machine while it is in operation. Stop machine if anyone enters the area.
- Thoroughly inspect the area where the equipment is to be used. Remove all stones, sticks, wire, bones, toys and other foreign objects which could be tripped over or picked up and thrown by the blade. Thrown objects can cause serious personal injury.
- Plan your mowing pattern to avoid discharge of material toward roads, sidewalks, bystanders and the like. Also, avoid discharging material against a wall or obstruction which may cause discharged material to ricochet back toward the operator.
- Always wear safety glasses or safety goggles during operation and while performing an adjustment or repair to protect your eyes. Thrown objects which ricochet can cause serious injury to the eyes.
- Wear sturdy, rough-soled work shoes and close-fitting slacks and shirts. Shirts and pants that cover the arms and legs and steel-toed shoes are recommended. Never operate this machine in bare feet, sandals, slippery or light weight (e.g. canvas) shoes.
- Many injuries occur as a result of the mower being pulled over the foot during a fall caused by slipping or tripping. Do not hold on to the mower if you are falling; release the handle immediately.
- Never pull the mower back toward you while you are walking. If you must back the mower away from a wall or obstruction first look down and behind to avoid tripping and then follow these steps:
 - a) Step back from the mower to fully extend your arms.
 - b) Be sure you are well balanced with sure footing.
 - c) Pull the mower back slowly, no more than half way toward you.
 - d) Repeat these steps as needed.
- Do not operate the mower while under the influence of alcohol or drugs.
- Do not put hands or feet near rotating parts or under the cutting deck. Contact with the blade can amputate hands and feet.
- A missing or damaged discharge cover can cause blade contact or thrown object injuries.
- Do not engage the self-propelled mechanism on units so equipped while starting engine.
- Never attempt to make a wheel or cutting height adjustment while the engine is running.
- The blade control handle is a safety device. Never attempt to bypass its operation. Doing so makes the safety device inopera-

tive and may result in personal injury through contact with the rotating blade. The blade control handle must operate easily in both directions and automatically return to the disengaged position when released.

- Never operate the mower in wet grass. Always be sure of your footing. A slip and fall can cause serious personal injury. If you feel you are losing your footing, release the blade control handle immediately and the blade will stop rotating within three seconds.
- Mow only in daylight or in good artificial light. Walk, never run.
- Stop the blade when crossing gravel drives, walks or roads.
- If the equipment should start to vibrate abnormally, stop the engine and check immediately for the cause. Vibration is generally a warning of trouble.
- Shut the engine off and wait until the blade comes to a complete stop before removing the grass catcher or unclogging the chute. The cutting blade continues to rotate for a few seconds after the engine is shut off. Never place any part of the body in the blade area until you are sure the blade has stopped rotating.
- Never operate mower without proper trail shield, discharge cover, grass catcher, blade control handle or other safety protective devices in place and working. Never operate mower with damaged safety devices. Failure to do so, can result in personal injury.
- Muffler and engine become hot and can cause a burn. Do not touch.
- Only use parts and accessories made for this machine by the manufacturer. Failure to do so, can result in personal injury.
- If situations occur which are not covered in this manual, use care and good judgment. Contact your customer support department.

SLOPE OPERATION

Slopes are a major factor related to slip and fall accidents which can result in severe injury. Operation on slopes requires extra caution. If you feel uneasy on a slope, do not mow it. For your safety, use the slope gauge included as part of this manual to measure slopes before operating this unit on a sloped or hilly area. If the slope is greater than 15 degrees, do not mow it.

DO:

- Mow across the face of slopes; never up and down. Exercise extreme caution when changing direction on slopes. Watch for holes, ruts, bumps, rocks, or other hidden objects which can cause you to slip or trip. Tall grass can hide obstacles. Always be sure of your footing. A slip and fall can cause serious personal injury. If you feel you are losing your balance, release the blade control handle immediately, and the blade will stop rotating within 3 seconds.

DO NOT:

- Do not mow near drop-offs, ditches or embankments, you could lose your footing or balance.
- Do not mow slopes greater than 15 degrees as shown on the slope gauge.
- Do not mow on wet grass. Unstable footing could cause slipping.

CHILDREN

- Tragic accidents can occur if the operator is not alert to the presence of children. Children are often attracted to the mower and the mowing activity. They do not understand the dangers. Never assume that children will remain where you last saw them.
 - a) Keep children out of the mowing area and under the watchful care of a responsible adult other than the operator.
 - b) Be alert and turn mower off if a child enters the area.
 - c) Before and while moving backwards, look behind and down for small children.
 - d) Use extreme care when approaching blind corners, doorways, shrubs, trees, or other objects that may obscure your vision of a child who may run into the mower.
 - e) Keep children away from hot or running engines. They can suffer burns from a hot muffler.
- Never allow children under 14 years old to operate a power mower. Children 14 years old and over should read and understand the operation instructions and safety rules in this manual and should be trained and supervised by a parent.

SERVICE SAFE HANDLING OF GASOLINE:

- To avoid personal injury or property damage use extreme care in handling gasoline. Gasoline is extremely flammable and the vapors are explosive. Serious personal injury can occur when gasoline is spilled on yourself or

your clothes which can ignite. Wash your skin and change clothes immediately.

- a) Use only an approved gasoline container.
- b) Never fill containers inside a vehicle or on a truck or trailer bed with a plastic liner. Always place containers on the ground away from your vehicle before filling.
- c) When practical, remove gas-powered equipment from the truck or trailer and refuel it on the ground. If this is not possible, then refuel such equipment on a trailer with a portable container, rather than from a gasoline dispenser nozzle.
- d) Keep the nozzle in contact with the rim of the fuel tank or container opening at all times until fueling is complete. Do not use a nozzle lock-open device.
- e) Extinguish all cigarettes, cigars, pipes and other sources of ignition.
- f) Never fuel machine indoors.
- g) Never remove gas cap or add fuel while the engine is hot or running. Allow engine to cool at least two minutes before refueling.
- h) Never over fill fuel tank. Fill tank to no more than $\frac{1}{2}$ inch below bottom of filler neck to provide space for fuel expansion.
- i) Replace gasoline cap and tighten securely.
- j) If gasoline is spilled, wipe it off the engine and equipment. Move unit to another area. Wait 5 minutes before starting the engine.
- k) Never store the machine or fuel container inside where there is an open flame, spark or pilot light as on a water heater, space heater, furnace, clothes dryer or other gas appliances.
- l) To reduce fire hazard, keep machine free of grass, leaves, or other debris build-up. Clean up oil or fuel spillage and remove any fuel soaked debris.
- m) Allow machine to cool at least 5 minutes before storing.

GENERAL SERVICE:

- Never run an engine indoors or in a poorly ventilated area. Engine exhaust contains carbon monoxide, an odorless and deadly gas.
- Before cleaning, repairing, or inspecting, make certain the blade and all moving parts have stopped. Disconnect the spark plug wire and ground against the engine to prevent unintended starting.
- Check the blade and engine mounting bolts at frequent intervals for proper tightness. Also, visually inspect blade for damage (e.g., bent, cracked, worn) Replace blade with the original equipment manufacturer's (O.E.M.) blade only, listed in this manual. "Use of parts which do not meet the original equipment specifications may lead to improper performance and compromise safety!"
- Mower blades are sharp and can cut. Wrap the blade(s) or wear gloves, and use extra caution when servicing them.
- Keep all nuts, bolts, and screws tight to be sure the equipment is in safe working condition.
- Never tamper with safety devices. Check their proper operation regularly.
- After striking a foreign object, stop the engine, disconnect the spark plug wire and ground against the engine. Thoroughly inspect the mower for any damage. Repair the damage before starting and operating the mower.
- Grass catcher components, discharge cover, and trail shield are subject to wear and damage which could expose moving parts or allow objects to be thrown. For safety protection, frequently check components and replace immediately with original equipment manufacturer's (O.E.M.) parts only, listed in this manual. "Use of parts which do not meet the original equipment specifications may lead to improper performance and compromise safety!"
- Do not change the engine governor setting or overspeed the engine. The governor controls the maximum safe operating speed of the engine.
- Maintain or replace safety and instruction labels, as necessary.
- Observe proper disposal laws and regulations. Improper disposal of fluids and materials can harm the environment.

SI-102
7.23.03

OWNER'S
MANUAL



SAFETY LABEL



WARNING - Your Responsibility:

Restrict the use of this power machine to persons who read, understand and follow the warnings and instructions in this manual and on the machine.

SLOPE GAUGE

(Keep this sheet in a safe place for future reference.)

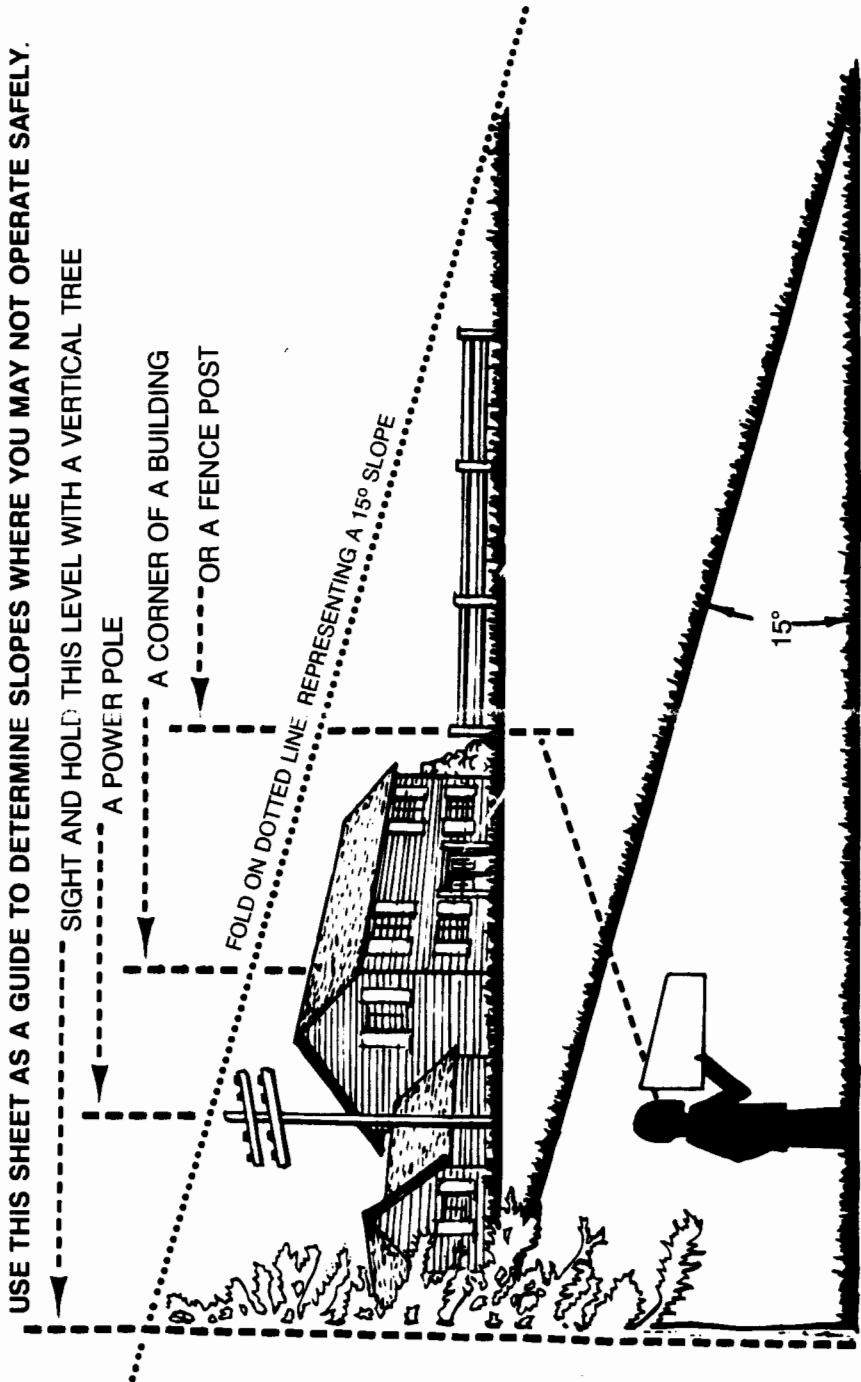

USE THIS SHEET AS A GUIDE TO DETERMINE SLOPES WHERE YOU MAY NOT OPERATE SAFELY.

▲ DANGER

Do not mow on inclines with a slope in excess of 15 degrees (a rise of approximately 2½ feet every 10 feet). A riding mower could overturn and cause serious injury. If operating a walk-behind mower on such a slope, it is extremely difficult to maintain your footing and you could slip, resulting in serious injury.

Operate RIDING mowers up and down slopes, never across the face of slopes.

Operate WALK-BEHIND mowers across the face of slopes, never up and down slopes.

It is suggested that this manual be read in its entirety before attempting to assemble or operate. Keep this manual in a safe place for future reference and for ordering replacement parts.

This unit is shipped **WITHOUT GASOLINE or OIL**. After assembly, service engine with gasoline and oil as instructed in the separate engine manual packed with your unit.

NOTE: Reference to right or left hand side of the mower is observed from the operating position.

UNPACKING

REMOVING UNIT FROM CARTON

- Remove staples, break glue on top flaps, or cut tape at carton end and peel along top flap to open.
- Remove loose parts included with unit (i.e., operator's manual, oil, etc.).
- Cut corners and lay carton down flat. Remove packing material.
- Roll or slide unit out of carton. Check carton thoroughly for loose parts.

CAUTION: DO NOT BEND OR KINK CABLES.

TOOLS REQUIRED

Pair of Pliers Funnel

ASSEMBLY

CAUTION: DISCONNECT SPARK PLUG WIRE. IF THE WIRE IS NOT EQUIPPED WITH A RUBBER BOOT, SEE SEPARATE ENGINE MANUAL FOR GROUNDING PROCEDURE.

- Remove grass bag from the unit and set it out of the way. See Figure 1, step 1.
- Remove any packing material which may be between the upper and lower handles for shipping purposes.
- Raise the lower handle in the direction shown in Figure 1, step 2 till it snaps into place.
- Raise the upper handle in the direction shown in Figure 1, step 3. Tighten the wing nuts which are already on the handle. See Figure 2.
- Pull the drive control handle all the way back.
- While holding the drive control handle, hook the "Z" end of the drive cable into the bot-

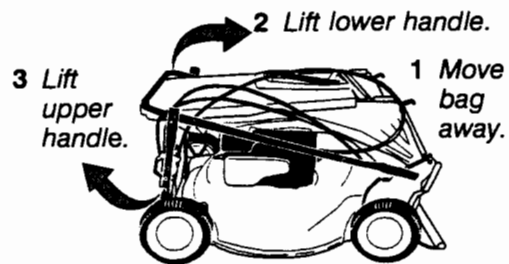

Figure 1

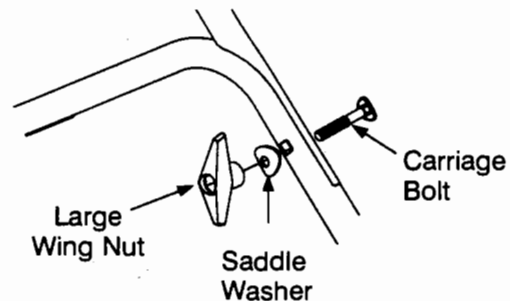

Figure 2

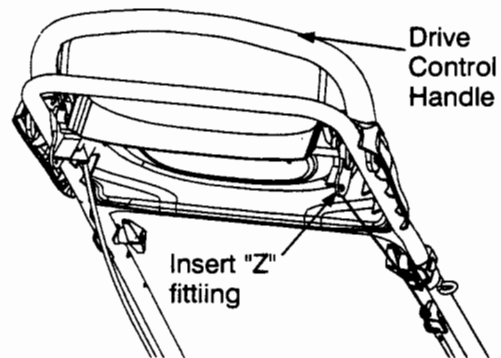
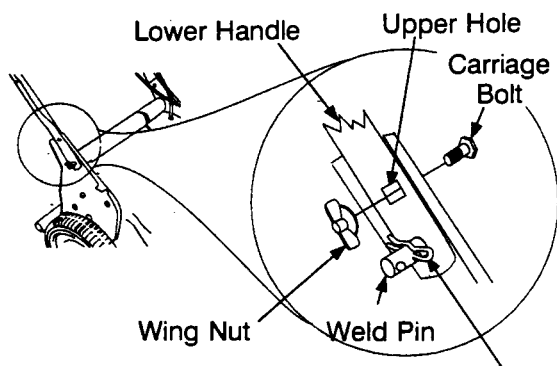

Figure 3

tom hole of the drive control handle from inside to outside. See Figure 3.

NOTE: Make certain the drive cable is routed around the outside and above the lower handle so it does not interfere with attaching the grass bag.

- Attach drive cable to the lower handle with one cable tie. Insert peg on cable tie into the hole on the lower handle. Pull cable tie tight and cut off the extra.
- For shipping purposes, the hairpin clip is placed in the outer hole of the weld pin on the lower handle. Remove the hairpin clip from the outer hole of the weld pin. See Figure 4.
- Using a pair of pliers, insert the hairpin clip into the inner hole on the weld pin. Repeat on other side.



Place the hairpin clips in the inner hole.

Figure 4

- Insert the carriage bolt, included in the hardware pack, in the upper hole on the handle mounting bracket (carriage bolt must go to the inside of handle). See Figure 4. Secure with one plastic wing nut, also included in the hardware pack. Repeat on the other side with remaining items from the hardware pack.

ATTACHING DRIVE ADJUSTER BLOCK

- The drive adjuster block is attached to the drive cable.
- Remove bolt attached to the lower right handle.
- Align the drive adjuster block, curved side against handle, with hole in handle.
- Secure drive adjuster block with bolt previously removed. See Figure 5.

ATTACHING STARTER ROPE

- The rope guide and wing nut are attached to the starter rope, on top of the engine. Remove the wing nut from rope guide. Remove the rope guide from the starter rope.
- With the spark plug wire disconnected and grounded as instructed in the separate engine manual, hold the blade control handle against the upper handle, and pull the starter rope out of the engine. Hold the rope guide as shown so the opening in the rope guide is toward the front of mower. Slip the rope guide around the starter rope and into the right side of lower handle using the hole shown. Secure using the small wing nut. See Figure 5.
- Make certain all nuts and bolts are tightened securely.

ASSEMBLY OF GRASS CATCHER

NOTE: If your mower's grass catcher is assembled, proceed to the next section. If not, follow these steps.

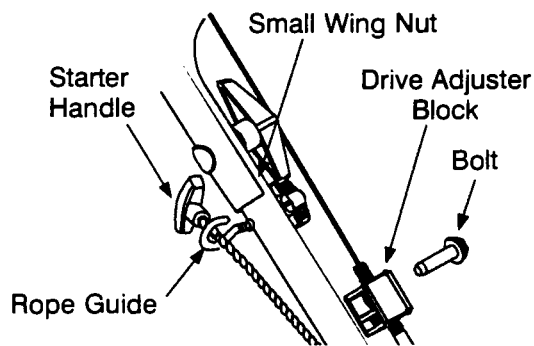

Figure 5

Soft Grass Bag

NOTE: Make certain the grass bag is turned right side out before assembling (warning label will be on the outside).

- Place bag over frame (black plastic side is the bottom of bag.) Insert the hooks on the frame through the holes in the side plastic channels of the bag. See Figure 6.
- Secure bag to frame by working the plastic channels on bag over frame as shown in Figure 6. All of the plastic channels except center top of bag attach from the outside of bag. Center top of bag attaches from the inside of bag.

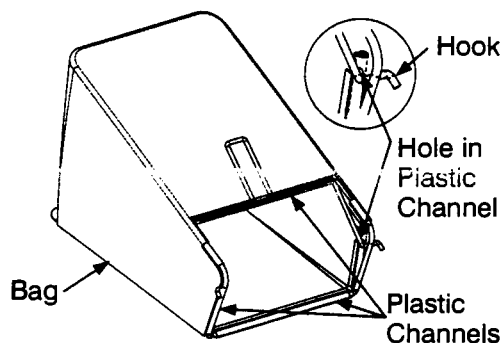

Figure 6

ATTACHING GRASS CATCHER TO MOWER

- Lift the rear discharge door on the mower, and place the grass catcher on the pivot rod. Let go of discharge door so that it rests on the grass catcher. See Figure 7.

NOTE: Make certain cables are routed to the outside of the handle so they are not in the way when attaching the grass catcher.

TO REMOVE THE GRASS CATCHER

- Lift the rear discharge door on the mower as shown in Figure 7. Lift the grass catcher up

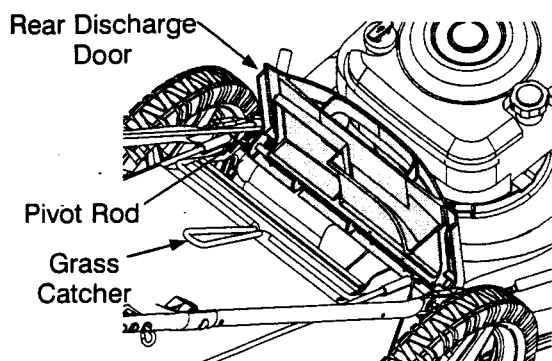

Figure 7

and off the pivot bar. Release the rear discharge door.

WARNING: Never operate the mower unless the hooks on the grass catcher are seated on the pivot rod, and the rear discharge door rests firmly against the top of the grass catcher.

CONVERTING TO SIDE DISCHARGE

If your unit is equipped with a side discharge deflector, you can convert to a side discharge mower as follows:

- Remove the grass catcher as previously described.
- On the side of the mower deck, lift the hinged mulching plug. See Figure 8.
- Slide the two hooks on the side discharge deflector under the hinge pin on the hinged mulching plug assembly.
- Lower the hinged mulching plug.

NOTE: Do not remove the hinged mulching plug at any time, even when you are not mulching.

WARNING: All mowers are equipped with a rear protective guard. The guard helps eliminate projectiles thrown by the blade from injuring the operator. **DO NOT REMOVE THIS GUARD.**

Hinged Mulching Plug

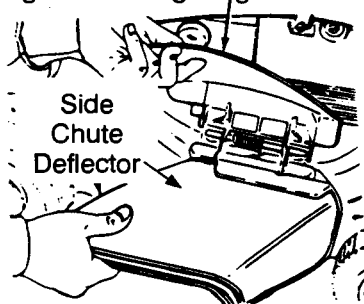

Figure 8

CONVERTING TO MULCHER

- Remove the grasscatcher.
- If the unit was set up for side discharge, lift the hinged mulching plug on the side of the deck and remove the side discharge chute. Lower the hinged mulch plug. See Figure 8.

CAUTION: Do not run your lawn mower without chute deflector, mulching plug or an approved grass catcher in place. The deflector will deflect a projectile thrown by the blade into the lawn.

FINAL ASSEMBLY

- Check all nuts and bolts for correct tightness.

CONTROLS

Read this owner's manual and safety rules before operating your lawn mower. Compare Figure 9 with your lawn mower to familiarize yourself with the location of various controls and adjustments. Save this manual for future reference.

WARNING: The operation of any lawn mower can result in foreign objects being thrown into the operator's eyes thus causing severe eye damage. Always wear safety glasses while operating the mower, or while performing any adjustments or repairs on it.

Drive Control Handle

This mower is equipped with Smart Speed™ transmission which enables the drive control handle to adjust the mowing speed automatically with your walking. The drive control handle is located on the upper handle. Push the handle forward to engage drive, pull it backwards to stop. The farther the handle is pushed forward, the faster the mower will propel.

Blade Control Handle

The blade control handle is located on the upper handle of the mower. See Figure 9. The blade control handle must be depressed in order to operate the unit. Release the blade control handle to stop the engine and blade.

WARNING: The blade control handle is a safety device. Never attempt to bypass its operations.

Starter Rope

The starter rope is attached to the handle. Stand behind the unit and pull the starter rope to start the unit.

Throttle Control

The engine is equipped with a constant speed throttle which is set at full throttle for maximum engine and cutting performance.

Cutting Height Adjustment Lever

These levers are located on each wheel and they are used to adjust the cutting height. All four levers have to be at the same relative position to ensure uniform cut.

OPERATION

Service the engine with gasoline and oil as instructed in the separate engine manual packed with your mower. Read instructions carefully.

! WARNING: Never fill fuel tank indoors, with engine running or until the engine has been allowed to cool for at least two minutes after running.

BEFORE STARTING

- Attach spark plug wire to spark plug. If unit is equipped with a rubber boot over the end of the spark plug wire, make certain the metal loop on the end of the spark plug wire (inside the rubber boot) is fastened securely over the metal tip on the spark plug. See Figure 10.

TO START ENGINE AND ENGAGE BLADE

! WARNING: Be sure no one other than the operator is standing near the lawn mower while starting engine or operating mower.

! WARNING: Never run engine indoors or in enclosed, poorly ventilated areas. Engine exhaust contains carbon monoxide, an odorless and deadly gas.

! WARNING: Keep hands, feet, hair and loose clothing away from any moving parts on engine and lawn mower.

- If your unit is equipped with a primer, prime engine as instructed in the separate engine manual packed with your unit.

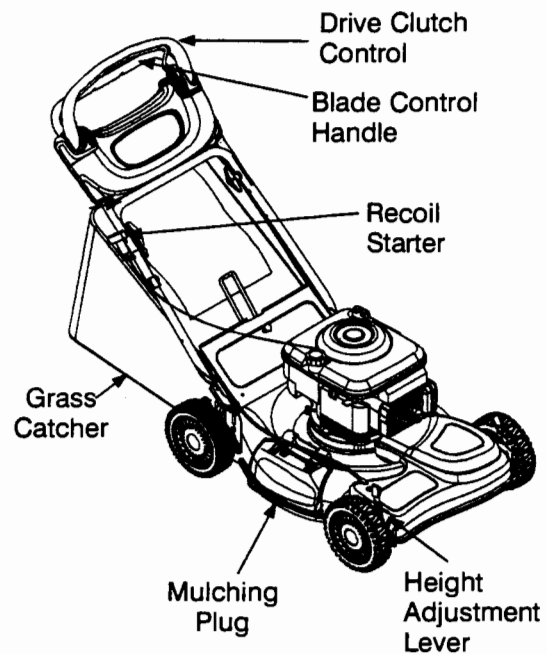

Figure 9 - The left rear wheel has been left out of the picture for clarity

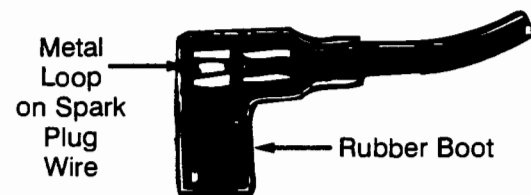

Figure 10

- If your unit is equipped with a two speed control on engine refer to separate engine manual packed with your unit.
- Standing behind the mower, depress the blade control handle and hold it against the drive control handle. Make sure the drive control handle is pulled all the way back.

! WARNING: If the drive control handle is not pulled all the way back, the mower will propel forward when started.

- Grasp the recoil starter handle and pull slowly until resistance is felt, then pull rapidly to start engine and avoid kickback. Return it slowly to the rope guide bolt.
- After the engine starts, push the handle forward to engage drive, pull it backwards to stop. Release the drive clutch control to slow down when negotiating an obstacle, making a turn, or stopping. The farther the handle is pushed forward, the faster the mower will propel.

NOTE: *The blade control handle must be depressed in order to operate the unit. Release the blade control handle to stop the engine and blade.*

TO STOP ENGINE

- Release the blade control handle to stop the engine and blade.
- Disconnect the spark plug wire as instructed in the separate engine manual to prevent accidental starting while equipment is unattended.



WARNING: The blade continues to rotate for a few seconds after the engine is shut off.



WARNING: If you strike a foreign object, stop the engine. Remove wire from spark plug, thoroughly inspect the mower for any damage, and repair the damage before restarting and operating the mower. Extensive vibration of the mower during operation is an indication of damage. The unit should be promptly inspected and repaired.

USING YOUR MULCHER (Optional)

Mulching mowers use a specially designed blade to chop the grass clippings extra fine and then blow them back down into the lawn. The small clippings decompose quickly becoming a natural fertilizer that returns much of the needed nutrients to the soil. Continuous mulching means continuous free natural fertilization, no messy clippings to worry about ever again and the end result for you is a much greener healthier lawn.



WARNING: Your mower is designed to cut normal residential grass of a height no more than 10". Do not attempt to mow through unusually tall, dry grass (e.g., pasture) or piles of dry leaves. Debris may build up on the mower deck or contact the engine exhaust presenting a potential fire hazard.

FOR THE BEST RESULTS WHEN MULCHING:

- **Clear lawn of debris.** Be sure that the lawn is clear of stones, sticks, wire or other foreign objects which could damage the lawnmower. Such objects could be accidentally thrown out by the mower in any direction and cause serious personal injury to the operator and others as well as damage to property and surrounding objects.
- **Do not cut wet grass.** For effective mulching do not cut wet grass because it tends to

stick to the underside of the deck preventing proper mulching of the grass clippings.

- **Cut no more than 1/3 the length of the grass.** The recommended cut for mulching is 1/3 the length of the grass. Ground speed will need to be adjusted so the clippings can be dispersed evenly into the lawn. For especially heavy cutting in thick grass it may be necessary to use one of the slowest speeds in order to get a clean well mulched cut. When mulching long grass you may have to cut the lawn in two passes, lowering the blade another 1/3 of the length for the second cut and perhaps cutting in a different pattern than was used the first time. Overlapping the cut a little on each pass will also help to clean up any stray clippings left on the lawn. The mower should always be operated at full throttle to get the best cut and allow it to do the most effective job of mulching.

- **Clean underside of deck.** Be certain to clean the underside of the cutting deck after each use to avoid a build-up of grass, which would prevent proper mulching.

- **Mulching Leaves.** The mulching of leaves can also be beneficial to your lawn. When mulching leaves make sure they are dry and are not laying too thick on the lawn. Do not wait for all the leaves to be off the trees before you mulch.

- It is recommended keeping driveways and sidewalks on the operators right while moving. Continue mowing using this pattern, having the left side of your lawnmower next to the uncut grass. Mulching with the cutting area of the mower on the lawn avoids grass clippings in undesirable areas.

DECK

The underside of the mower deck should be cleaned after each use to prevent a buildup of grass clippings, leaves, dirt or other matter. If this debris is allowed to accumulate, it will invite rust and corrosion, and may prevent proper mulching.

The deck may be cleaned by tilting the mower and scraping clean with a suitable tool (make certain the spark plug wire is disconnected).

NOTE: *We do not recommend the use of pressure washers or garden hose to clean your unit. These may cause damage to electric components, spindles, pulleys, bearings, or the engine. The use of water will result in shortened life and reduce serviceability.*

ADJUSTMENTS

CAUTION: DO NOT AT ANY TIME MAKE ANY ADJUSTMENT TO LAWNMOWER WITHOUT FIRST STOPPING THE ENGINE AND DISCONNECTING THE SPARK PLUG WIRE

Adjusting Cutting Height

- Stop mower and disconnect spark plug cable before changing mower cutting height.
- The wheel adjusters give you nine (9) different cutting positions. Medium is the best for most mowers.
- To change the height of cut, squeeze adjuster lever toward the wheel, moving up or down to selected height. See Figure 11.



Figure 11

NOTE: All wheels must be in the same height of cut.

- When cutting in heavy or moist grass, the rear of lawnmower may be raised higher to allow better discharge of the grass.

Adjusting Drive Clutch

The drive clutch adjustment wheel is located on the lower right handle and is used to tighten or loosen tension on the drive cable. Adjust this cable if:

- a) the mower does not propel itself; or
- b) the wheels hesitate with the drive control handle pushed forward.
- To adjust, rotate the adjustment wheel with your fingers, see Figure 12. Turn the wheel to the left to tighten the drive cable. Turn the wheel to the right to loosen the drive cable.

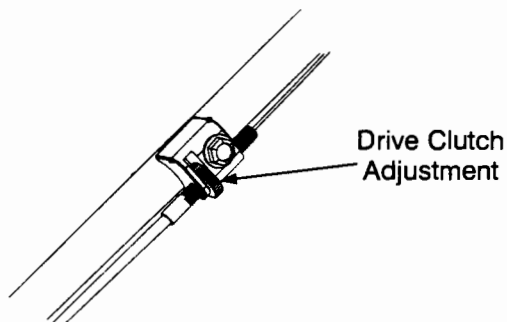

Figure 12

LUBRICATION

CAUTION: DISCONNECT SPARK PLUG WIRE BEFORE SERVICING

WHEELS - Lubricate the ball bearings (if so equipped) in each wheel at least once a season with a light oil. Also, if the wheels are removed for any reason, lubricate the surface of the axle bolt and the inner surface of the wheel with light oil. Engine oil may also be used.

ENGINE - Follow engine manual for lubrication instructions.

BLADE CONTROL - Lubricate the pivot points on the blade control handle and the brake cable at least once a season with light oil. The blade control must operate freely in both directions.

DISCHARGE DOORS - The torsion springs and pivot points should be lubricated periodically with light oil to prevent any rust or binding. Door must work freely.

TRANSMISSION - The transmission is pre-lubricated and sealed at the factory and does not require lubrication on a regular basis as part of maintenance.

MAINTENANCE

For best results your blade should be sharp. The blade may be resharpened by removing it and either grinding or filing the cutting edge keeping as close to the original bevel as possible.

Improper blade balance will result in excessive vibration causing eventual damage to the engine and mower. Be sure to carefully balance blade after sharpening.

After prolonged use, especially in sandy soil conditions, the blade will become worn and lose some of the original shape. Cutting efficiency will be reduced and the blade should be replaced. Replace with an approved factory replacement blade only. Possible damage resulting from blade unbalance condition is not the responsibility of the manufacturer.

NOTE: Tip mower as specified in separate engine manual. If not specified tip with carburetor up.

CUTTING BLADE

CAUTION: Cutting grass in sandy soil condition causes abrasive wear to the blade.



WARNING: When removing the cutting blade for sharpening or replacement, protect hands by using heavy gloves or a rag to grasp the cutting blade.

- Remove the bolt which hold the blade adapter-pulley assembly to the engine crankshaft. Remove the pulley assembly and the bell support from the crankshaft. See Figure 13.
- Remove the blade from the blade adaptor and pulley.

Installing the blade

- Before reassembling the blade-pulley assembly to the unit, lubricate the engine crankshaft and the inner surface of the blade adapter with light oil (or engine oil).
- Lubricating the bolt hole and hex bolt.
- Insert the hex bolt, earlier removed, through the center holes on the blade bell support and the blade adapter-pulley assembly respectively.
- Install the blade assembly up on the crankshaft. Tighten the hex bolt to the torque listed below.

IMPORTANT: The bolt, used to secure the blade to the engine, is especially heat-treated. **Do not substitute.** To order replacement bolt, refer to the parts listed in the middle of this manual.

Blade Mounting Torque

Center Bolt: 450 in. lbs. min., 600 in. lbs. max.

To ensure safe operation of your unit, all nuts and bolts must be checked periodically for correct tightness.

ENGINE

Refer to the separate engine manual for engine maintenance instructions.

Maintain **engine oil** as instructed in the separate engine manual packed with your unit. Read and follow instructions carefully.

Under normal conditions service **air cleaner** as instructed in the separate engine manual packed with your unit. Clean every few hours under extremely dusty conditions. Poor engine performance and flooding usually indicates that the air cleaner should be serviced.

The **spark plug** should be cleaned and the gap reset once a season. Spark plug replacement is recommended at the start of each

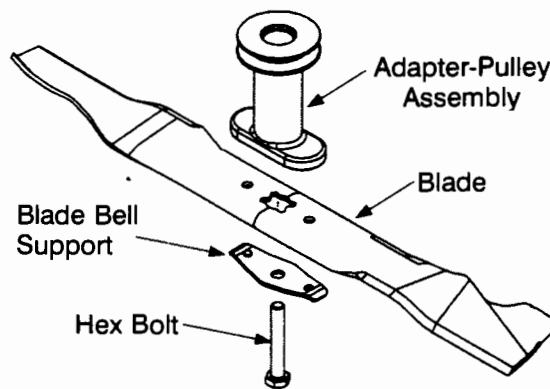

Figure 13

mowing season; check engine manual for correct plug type and gap specifications.

NOTE: This spark ignition system meets all requirements of the Canadian Interference-Causing Equipment Regulations.

Clean the engine regularly with a cloth or brush. Keep the cooling system (blower housing area) clean to permit proper air circulation which is essential to engine performance and life. Be certain to remove all grass, dirt and combustible debris from muffler area.

REAR FLAP REPLACEMENT

The rear flap is attached to the back of the mower deck, and is designed to minimize the possibility that objects will be thrown from the rear of the mower toward the operator. If the rear flap becomes damaged, replace as follows.

To remove the old rear flap, cut off the flat end of the wire rod which secures it to the deck using a pair of side-cutters. Attach the new rear flap using the new rod provided with the rear flap, bending the ends of the rod over to secure.

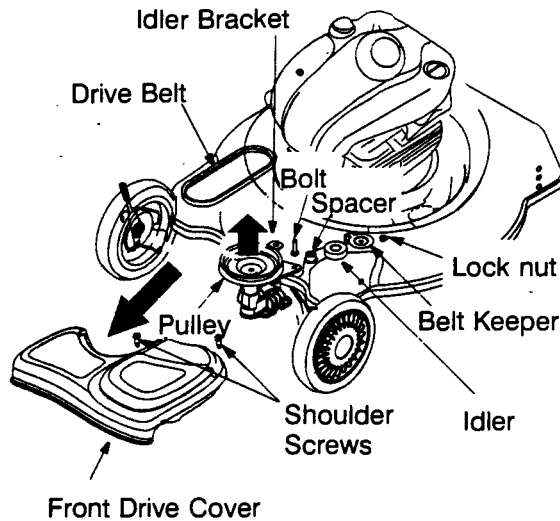

Figure 15

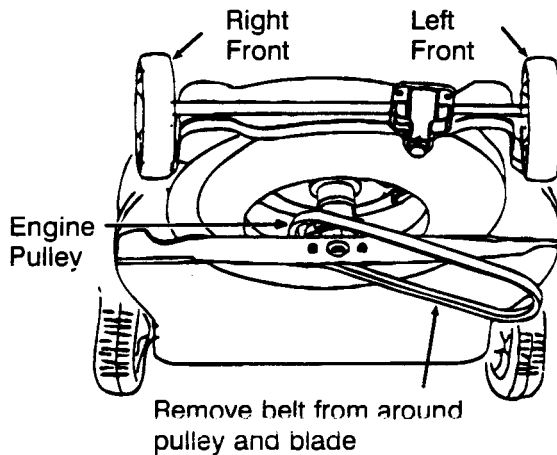

Figure 15

BELT REMOVAL AND REPLACEMENT

- Remove the two shoulder screws from on top of the deck which secures the front drive cover to the mower deck. See Figure 14.
- Remove the front drive cover from the unit by lightly pressing inward on the sides of the front drive cover. This will release the tabs that secure the front drive cover to the height adjuster brackets. See Figure 14.

- Remove the idler from idler bracket using 7/16" wrench and socket. See Figure 14.
- Remove the belt from the transmission. See Figure 1.
- Remove the belt from the engine pulley and around the blade. See Figure 15.
- Reassemble in reverse order with new belt.

NOTE: Begin idler reassembly by inserting bolt up through the idler bracket hole.

- Adjust the Drive Clutch as instructed in "Adjusting Drive Clutch" Section.

OFF SEASON STORAGE INSTRUCTIONS

The following steps should be taken to prepare lawn mower for storage.

- Clean and lubricate mower thoroughly as described in the lubrication instructions.
- Refer to engine manual for correct engine storage instructions.
- Coat mower's cutting blade with chassis grease to prevent rusting.
- Store mower in a dry, clean area.

NOTE: When storing any type of power equipment in an unventilated or metal storage shed, care should be taken to rust-proof the equipment. Using a light oil or silicone, coat the equipment, especially cables and all moving parts.

NOTE: Be careful not to bend or kink cables.

NOTE: If the starter rope becomes disconnected from rope guide on handle, disconnect and ground the spark plug wire. Depress the blade control handle and pull the starter rope out from engine slowly. Slip the starter rope into the rope guide bolt on handle.